

THE DA 40 IN A 'CAPSULE'

CHAPTER 1

1. Max take off RPM- 2700.
2. Max take off mass 1200 kg.
3. The place to keep the airplane manual is in the side bag of the forward left seat.
4. Span: 11.94 m
Length: 8.01m
Height: 1.97m
5. Wing Area: 13.54 m sq.
MAC: 1.121m
AR: 10.53
Dihedral: 5 Deg
Sweep: 1 Deg
6. Aileron area: .654m sq (both ailerons)
7. Wing Flap area: 1.56m sq (Both flaps)
8. Horizontal tail:
Area: 2.34m sq
Elevator area: .665m sq
Angle of incidence: - 3 Deg relative to long axis of ac.

THE DA 40 IN A 'CAPSULE'

9. Vertical Tail:

Area: 1.60 sq m

Rudder area: .047 sq m.

2

OPERATING LIMITATIONS (CHAPTER 2)

10. Maneuvering speed limits (Va):

980 kg to 1150 Kg- 108 kts

780kg to 980 kg- 94 kts

With MAM 40-227 carried out:

1036 kg to 1200 kg- 111kts

780kg to 1036 kg- 94kts

11. Vfe: Max flap extension speed- LDG flaps- 91 KIAS.
Take off- 108 KIAS.

12. Max structural cruising speed (Vno): 129KIAS

13. Vne: 178KIAS

14. Prop dia: 74 Inch (Max) 72 Inch (Min)

15. Prop pitch angle: 35 Deg +/- 1 deg, to 13.5+-.2Deg, at 30 Inch station.

NOTE: THIS INFORMATION IS TO ASSIST YOU IN PREPARING FOR THE DGCA PAPER ONLY. THE POH REMAINS THE MASTER FOR FLYING AND SUPERSEDES THIS IN CASE OF ANY DISCREPANCY.

THE DA 40 IN A 'CAPSULE'

16. Green Arcs:	LOWER RED ARC	UPPER RED ARC
MAP: 13 – 30 in Hg	--	--
RPM: 500-2700	--	ABOVE 2700
Oil Temp- 149-230 F	--	ABOVE 245 F
CHT- 150-475 F	--	ABOVE 500 F
OIL PRESS: 56- 95PSI	25 PSI	ABOVE 97 PSI
FUEL PRESS: 14 – 35 PSI	14 PSI	ABOVE 35 PSI
VOLT- 25.1 to 30 V	24.1V	ABOVE 32 V
AMMETER- 2-75 A	--	--
FUEL QUANTITY (STD TANK)	0-15/0-17	
FUEL QUANTITY (LG RANGE)	0-16 + 0-9 US GAL	
Oil quantity min-	4 quarts, max 8 quarts.	

17. There are two types of annunciator panels: DAI and white wire.

18. Warning light for oil press- Oil press below 25 PSI

19. Warning light for fuel press- Press below 14 PSI

20. CAUTION LIGHT FOR FUEL INDICATES US GAL 3 +- 1GAL IN TANK.

21. Maximum take off mass Normal -1150 kg

MAM 40-227 MODIFIED- 1200 KG

22. Maximum landing mass: (Original Strut) - 1092 kg

NOTE: THIS INFORMATION IS TO ASSIST YOU IN PREPARING FOR THE **DGCA PAPER ONLY**. THE **POH** REMAINS THE **MASTER** FOR FLYING AND SUPERSEDES THIS IN CASE OF ANY DISCREPANCY.

THE DA 40 IN A 'CAPSULE'

23. Maximum landing mass: (Modified strut) - 1150 Kg
24. Max load in baggage compartment: 30 Kg
25. Max load in baggage tube: 5 Kg
26. The most forward position of CG is
- a) 2.40m aft of datum point upto 980 kg.
 - b) 2.46m aft of datum point upto 1150kg.
 - c) 2.48m aft of datum point upto 1200 kg.
27. The most rearward position of CG is
- a) 2.59m aft of datum point with standard tank
 - b) 2.55 m aft of DP with long range tanks.
28. The normal category ac can carry out maneuvers up to AOB of 60 deg.
29. Utility category can maneuver up to AOB of 90 deg, but AH and DG are affected by AOB over 60 deg.
30. Load factors. Normal/(Utility)Category aircraft.

	AT Va	AT Vne	With Flap Down
Positive	3.8g (4.4)	3.8(4.4)	2.0
Negative	-1.52 (-1.76)	Nil (-1)	Nil

31. The maximum demonstrated operating altitude is 16,400 feet/5000mtrs.

NOTE: THIS INFORMATION IS TO ASSIST YOU IN PREPARING FOR THE DGCA PAPER ONLY. THE POH REMAINS THE MASTER FOR FLYING AND SUPERSEDES THIS IN CASE OF ANY DISCREPANCY.

THE DA 40 IN A 'CAPSULE'

32. Flights into known icing conditions are prohibited and also into known thunderstorms.

33. Maximum number of occupants in normal category is 4 and minimum is 1. Max in utility category is 2.

34. Fuel type is AV Gas 100LL.

35. Total fuel quantity: 20.6 X 2 US gal or appx 78 X 2 litres.

36. Total unusable fuel is 2 X .5 US gal or appx 2 X 2 litres.

37. Fuel indication is by capacitance.

38. Upto serial no 40.054 the gauge shows 15 US gallons.

39. Serial no 40.055 and above the fuel gauge shows 17 US gal.

40. Arcs of the ASI.

MARKING	IAS	IMP
WHITE ARC	49-91 KIAS	FULL FLAP OP LIMIT
GREEN ARC	52-129 KIAS	NORMAL OP LIMIT OF AC
YELLOW ARC	129-178 KIAS	CAUTION RANGE – SMOOTH AIR ONLY
RED LINE(Vne)	178 KIAS	MAXIMUM SPD IN ALL CONDITIONS.

41. Max difference in fuel between Lt and Rt tank is 10 US Gallons for standard tanks.

42. Max difference in fuel between Lt and Rt tank is 08 US Gallons for long range tanks.

NOTE: THIS INFORMATION IS TO ASSIST YOU IN PREPARING FOR THE DGCA PAPER ONLY. THE POH REMAINS THE MASTER FOR FLYING AND SUPERSEDES THIS IN CASE OF ANY DISCREPANCY.

THE DA 40 IN A 'CAPSULE'

43. The oil used in the DA 40 is SAE 15W50.
44. The min/max oil required in VFR is 4-8 Quarts.
45. The min/max oil required in IFR is 6-8 Quarts.
46. Max spd with full flap deflection is 91 KIAS.
47. Max spd with partial flap deflection is 108 KIAS.
48. If alternative static is open emergency window and cockpit Vent must be closed.
49. The airplane must not be operated below -40 deg centigrade.
50. IFR flights not permitted with emergency seal broken.
51. Incase of electrical fail then the essential bus will have power for 30 minutes.
52. The emergency battery will supply power for 1.5 hours only. They will supply the AH and flood lights.

CHAPTER 3 (EMERGENCY PROCEDURES)

50. Air speeds in emergencies. Engine failure after takeoff flaps T/O:
850KG: 59KIAS, 1000 KG: 66 KIAS, 1150 KG: 72 KIAS, 1200 KG: 74 KIAS
SPEED AT WHICH TAKEOFF CANNOT BE ABORTED
850KG: 59KIAS, 1000 KG: 66 KIAS, 1150 KG: 72 KIAS, 1200 KG: 74 KIAS
51. Air speed for best glide flaps up:
850KG: 60KIAS, 1000 KG: 68 KIAS, 1150 KG: 73 KIAS, 1200 KG: 76 KIAS

NOTE: THIS INFORMATION IS TO ASSIST YOU IN PREPARING FOR THE DGCA PAPER ONLY. THE POH REMAINS THE MASTER FOR FLYING AND SUPERSEDES THIS IN CASE OF ANY DISCREPANCY.

THE DA 40 IN A 'CAPSULE'

52. Air speed for Ldg engine off flaps up:

850KG: 60KIAS, 1000 KG: 68 KIAS, 1150 KG: 73 KIAS, 1200 KG: 76 KIAS

Air speed for Ldg engine off flaps take off:

850KG: 59KIAS, 1000 KG: 66 KIAS, 1150 KG: 72 KIAS, 1200 KG: 74 KIAS

Air speed for Ldg engine off flaps landing:

850KG: 58KIAS, 1000 KG: 63 KIAS, 1150 KG: 71 KIAS, 1200 KG: 73 KIAS

53. Engine rough running in air:

850KG: 60 KIAS, 68 KIAS (1000KG), 73 KIAS (1150kg), 76 KIAS (1200kg)

54. Restarting engine in the air wind-milling prop

:Min Speed 70 KIAS, Max speed Vne

: Min speed for wind milling 65 KIAS

: Recommended speed to fly is 80 KIAS.

55. Restarting in air with stationary prop: Min Speed 80 KIAS

56. Ht loss to start engine with prop stationary: 1000 ft/300m

57. Emergency elect system powers AH and floodlight in IFR version of DA 40.

58. Gliding spd of ac with flaps up is 76 KIAS for 1200kg, 73 KIAS for 1150 Kg, 68 KIAS for 1000 kg and 60 KIAS for 850 Kg.

59. The glide ratio is 1: 8.8 in wind milling configuration and for every 1000 ft ht loss the ac travels 1.45 Nm.

THE DA 40 IN A 'CAPSULE'

60. When the propeller is stationary then the glide ratio is 1: 10.3 and the ac travels 1.7 Nm for every 1000 feet loss of height.

8

61. Emergency landing speed engine off:

850KG: 60KIAS, 1000 KG: 68 KIAS, 1150 KG: 73 KIAS, 1200 KG: 76 KIAS

62. Spin recovery actions: Throttle IDLE, Opposite rudder, Control stick forward, ailerons neutral, Flaps up. When rotation stops, rudder neutral, stick back and ease out keeping below Vne.

63. Incase of suspected CO presence in cockpit front canopy can be unlatched in during flight. Flight characteristics will not vary greatly. Visual alert/(alarm comes on) illuminates and red light stays on. Page 3-37a

CHAPTER 4A (NORMAL OPERATING PROCEDURES)

64. Airspeed for climb after T/O. Vy or Best ROC with flaps to toff.

850KG: 54KIAS,1000 KG: 60 KIAS,1150 KG: 66 KIAS,1200 KG: 67 KIAS

65. Airspeed for cruise climb.

850KG: 60 KIAS, 1000 KG: 68 KIAS, 1150 KG: 73 KIAS, 1200 KG: 76 KIAS

66. Approach speed. Flaps to landing position.

850KG: 58KIAS, 1000 KG: 63 KIAS, 1150 KG: 71 KIAS,1200 KG: 73 KIAS

67. Minimum spd during touch and go. Flaps to takeoff.

850KG: 54KIAS, 1000 KG: 60 KIAS, 1150 KG: 66 KIAS,1200 KG: 67 KIAS

68. The main tire inflation press is 36 PSI and nose tire inflation pressure is 29 PSI.

NOTE: THIS INFORMATION IS TO ASSIST YOU IN PREPARING FOR THE DGCA PAPER ONLY. THE POH REMAINS THE MASTER FOR FLYING AND SUPERSEDES THIS IN CASE OF ANY DISCREPANCY.

THE DA 40 IN A 'CAPSULE'

69. Do not operate starter motor for more than 10 sec and let it cool for 20 sec. After 06 attempts to start let motor cool for 30mins.
70. If ambient temp is below 0 Deg cel then pre heat and ext power source is recommended.
71. Warm up engine at 1500 RPM for 2-5 minutes.
72. Oil press should be in green sector within 15 sec of starting. If not then, switch off.
73. Fuel press should be 14 to 35 PSI.
74. Idle rpm should be 600-800 RPM.
75. Nose wheel lift off speed is 59 KIAS. (Page 4a- 25)
76. To prevent vapor lock at high ambient temperatures run engine at speeds of 1800 RPM or more.
77. To check both tanks are feeding run at 1500 RPM for 01 minute.
78. In magneto check Max RPM drop permitted is 175 RPM and max difference is 50 RPM.
79. Take off spd at 1150 KG is 66 KIAS and at 1200 KG is 67 KIAS. (Page 4A -25a.)
80. CHT should be between 150 – 400 deg Fahrenheit and should not exceed 435 deg F in fast cruise. MAX CHT is 500 deg F.
81. Best economy mixture is at 75% power, to achieve it lean mixture till engine runs rough and then enrich till the smooth running and EGT is maximum.
82. The best power mixture is at 75 % Power and the enrich till EGT is 100 Deg F lower.

THE DA 40 IN A 'CAPSULE'

83. When reducing power the CHT should not drop more than 50 deg F per minute. 10
84. Approach speed for 1200 KG mass is 73 KIAS and for 1150 Kg mass it is 71 KIAS.
85. Go around speed is 67 KIAS for 1200 Kg and 66 KIAS for 1150 kg.

ABNORMAL OPERATIONS (CHAPTER 4B)

86. Precautionary approach speed is 76 KIAS for 1200 kg ac and 73 KIAS for 1150 Kg ac. Land on level / upward slope.
87. If the oil temp reads constant 26 deg F or 317 deg F then the sensor is at fault.
88. Take off speed from short grass strip. 67 KIAS for 1200 kg ac and 66 KIAS for 1150 kg ac.
89. Landing with flap up or flaps to take off: for 1200 kg ac use 76 KIAS and for 1150 kg ac use 73 KIAS.

CHAPTER V (PERFORMANCE)

90. At ISA + 15 deg C the ac engine power deteriorates by 3% and at ISA – 15 Deg C it improves by 3%.

91. Stalling speeds: ST AND LEVEL

1200 KG FLAPS UP : 53 KIAS	1150 KG FLAPS UP: 52 KIAS
T/O : 52 KIAS	T/O : 51 KIAS
LDG : 52 KIAS	LDG : 49 KIAS

92. Max cross wind component is 20 KIAS.
93. Lift off speed is 59 KIAS and climb out speed is 67 KIAS for 1200 kg and 66 KIAS for 1150 kg ac.

NOTE: THIS INFORMATION IS TO ASSIST YOU IN PREPARING FOR THE DGCA PAPER ONLY. THE POH REMAINS THE MASTER FOR FLYING AND SUPERSEDES THIS IN CASE OF ANY DISCREPANCY.

THE DA 40 IN A 'CAPSULE'

11

94. The climb gradient of the DA 40 is 7 % on go around with flaps to LDG the speed is to be maintained 73 KIAS.
95. The correct fuel indication of quantity takes 2 minutes to register after switch actuation.
96. The Datum Plane is 2.194 m ahead of the most forward point of the root wing on the stub wing.
97. The mass of fuel is taken to be .72 kg/ liter and engine oil is .89 kg/liter.

POH OF DA 40 (SECTION 7)

98. The fuselage is made of GFRP and is semi-monocoque in construction.
99. The wings are designed with one spar in the front and one in the rear. It is based on the Fail Safe concept.
101. The airplane has a T tail and is GFRP construction.
102. The stabilizers have twin spars and the skin has no sandwich.
103. The rudders and elevator are of sandwich construction.
104. The ailerons, elevator and flaps are operated by control rods. The rudder is operated by cables. Flaps are electrically operated. Trim Tab is operated by a Bowden Cable.
105. Flaps are made of GFRP/CFRP composite sandwich.
106. The flaps have three settings. UP, TOFF and LDG
107. The UP and LDG positions of the flaps are protected by a limit switch.

NOTE: THIS INFORMATION IS TO ASSIST YOU IN PREPARING FOR THE DGCA PAPER ONLY. THE POH REMAINS THE MASTER FOR FLYING AND SUPERSEDES THIS IN CASE OF ANY DISCREPANCY.

THE DA 40 IN A 'CAPSULE'

12

108. Flaps up position is shown by a Green Light and Flap down is shown by a White Light.
109. When flaps are travelling both lights will be on.
110. The flap system is protected by an automatic circuit breaker which can be operated manually.
111. The rudder pedals should be adjusted only on ground.
112. To move pedal forward depress lower side switch. To move pedals rearward depress upper side switch.
113. The main landing gear is of sprung steel struts and the free casting nose wheel is sprung by an elastomer package.
114. The wheel brakes are on the main wheel and are disk type and are hydraulically operated by toe pedals.
115. The DA 40 can have three types of baggage compartment and without a baggage net no baggage can be loaded.
116. The canopy has a cooling gap position and which can be used only on ground.
117. For flying the canopy must be locked and closed but not blocked with locking device.
118. The power plant is air cooled, four stroke, four cylinder, horizontally opposed direct driven with fuel injection system.
119. Displacement of the engine is 5916 Cm cube/ 361 inch cube.

NOTE: THIS INFORMATION IS TO ASSIST YOU IN PREPARING FOR THE DGCA PAPER ONLY. THE POH REMAINS THE MASTER FOR FLYING AND SUPERSEDES THIS IN CASE OF ANY DISCREPANCY.

THE DA 40 IN A 'CAPSULE'

120. The max power of the engine is 180 HP at 2700 RPM at sea level under ISA and 160 HP at 2400 RPM at SL at ISA.

121. The engine ignition switch has four positions OFF-L-R-BOTH positions and further right is the starter motor.

122. The engine is controlled with three levers: the throttle lever, the RPM lever and the Mixture control lever. They are black, blue and red respectively.

123. The RPM should not exceed 2700 RPM. The chosen RPM is maintained by the supply of engine oil. In case of defect in governor oil system the propeller goes to fine pitch(max rpm).

124. In case of governor failure the throttle should be used to control the RPM from exceeding 2700 RPM.

125. Alternate air supply is got for the engine from the engine compartment in case of icing/blocking of air filter.

126. The propeller is hydraulically regulated with a CSU and should never be rotated by hand with the ignition ON.

127. Operation at high RPM at ground to be avoided as blades can suffer stone damage.

128. The temperature of EGT and CHT and oil temperature is in Fahrenheit.

129. Oil and fuel press is in PSI. Fuel flow is in US gal/hr.

130. The fuel system is provided with an electrical and mechanical fuel pump. The electrical pump is for emergency and is used during

NOTE: THIS INFORMATION IS TO ASSIST YOU IN PREPARING FOR THE DGCA PAPER ONLY. THE POH REMAINS THE MASTER FOR FLYING AND SUPERSEDES THIS IN CASE OF ANY DISCREPANCY.

THE DA 40 IN A 'CAPSULE'

Take Off/Landing, while switching fuel tanks and in case of a fuel pressure decrease. It is to be checked at start up.

131. The fuel tank selector has three positions Left-Right-Off in clockwise pattern. The capacity of each tank is 20 US gallon and total ac fuel is 40 US gallons. The long range tanks have a capacity of 25 gallons each.

132. The fuel capacity measurement works on the principle of capacitance.

133. The maximum fuel indicated is 15 US gal upto 40.054 serial number and 17 US gal for 40.055 serial number onwards. When the indicator reads zero only unusable fuel remains in the tank. The total capacity for standard tanks is 20 US gallons.

134. The DA 40 has a 28 Volt DC system.

135. The alternator is rated at 70 Amps and charges the battery. If alt fails the battery provides the power.

136. The ac uses a lead acid battery with a capacity of 10 amps or more. In the IFR model an additional dry battery provides power to the AH and the flood lights for 1 hour and 30 minutes.

137. The master switch is divided into two parts, Master Switch(Alt) and Master Switch(Batt).

138. The DA 40 uses the SlickStart system and it gives a more spark energy at start. The LASAR electronic ignition can be installed in place of the former and it uses MAP and RPM to optimize engine timing.

NOTE: THIS INFORMATION IS TO ASSIST YOU IN PREPARING FOR THE DGCA PAPER ONLY. THE POH REMAINS THE MASTER FOR FLYING AND SUPERSEDES THIS IN CASE OF ANY DISCREPANCY.

THE DA 40 IN A 'CAPSULE'

15

139. If electronic ignition fails then the fail light comes on and conventional magneto ignition takes over.

140. While doing magneto check the ignition is not controlled electronically and then electronic ignition fail light should come on.

141. If electronic ignition is U/S then for engine start 500 RPM is required.

142. The magneto system is independent of electrical network and thus will provide safe engine operation in case of power failure.

143. The voltmeter gives the potential of the main bus. If alt is on line then voltage of alternator is shown or else batt volt is indicated.

144. The ammeter gives the current with which the alternator is loaded.

145. The landing/taxi lights are on the left wing.

146. Combined position and strobe lights are on the wing tips.

147. Floodlights brightness can be adjusted and it illuminates the inst panel and all levers.

148. The internal inst lighting is controlled by a rotary button.

149. The pitot heating system is protected by thermal fuse.

150. The **ALT** warning is **red** in color and only battery power is now available.

151. Low voltage caution comes on at 24 volts and goes off at 25 volts and is amber in colour.

NOTE: THIS INFORMATION IS TO ASSIST YOU IN PREPARING FOR THE DGCA PAPER ONLY. THE POH REMAINS THE MASTER FOR FLYING AND SUPERSEDES THIS IN CASE OF ANY DISCREPANCY.

THE DA 40 IN A 'CAPSULE'

16

152. **Fuel press wx** comes on at 14psi and is **red** in colour.
153. Fuel low level light comes on at 3 US gal +/- 1 US gal. The indication is calibrated for level flight only and is amber in colour.
154. **Oil press light** comes on at **25 psi and is red in colour**.
156. Door warning light comes on when front canopy or/and rear canopy is not closed and locked and is **red** in colour.
157. The battery is connected to the aircraft electrical system with a 70 amp circuit breaker.
158. The electronic ignition status light is white in colour.
159. The starter warning light is red in colour and comes on when the starter is being operated or when the connection between the starter motor and engine has not broken.
160. The pitot heating caution comes on when a) Pitot heater is off b) Malfunction of pitot heating system and when c) Thermal switch operates. The light is amber in colour.
161. A warning is indicated by the continuous aural alert, flashing of the red wx light and flashing of the red wx light associated with the system.
162. A caution is indicated by the momentary aural alert, flashing of the amber CAUTION light and flashing of the Amber Caution light associated with the system.
163. Low fuel light comes on when the fuel in any one tank is below 3 US gallon +/- 1US gallon. This is a caution alarm. When the second tank

NOTE: THIS INFORMATION IS TO ASSIST YOU IN PREPARING FOR THE DGCA PAPER ONLY. THE POH REMAINS THE MASTER FOR FLYING AND SUPERSEDES THIS IN CASE OF ANY DISCREPANCY.

THE DA 40 IN A 'CAPSULE'

17

fuel also drops to less than 3 US gallon +- 1US gallon then the alarm is continuous, caution light is flashed and the LOW FUEL light is flashed. On acknowledged also the LOW FUEL light continues to flash.

164. The pitot heater thermal switch operates to keep the probe from overheating. It resets automatically.

165. There are two static measuring orifices at the lower and rear edge of the probe.

166. If airspeed drops below 1.1 times the stalling speed then the stall warning horn sounds.

CHAPTER 8-AIRPLANE HDLG, CARE AND MAINTENANCE

167. For short term parking the airplane should be parked into the wind.

168. The control surface gust locks are used for locking the primary controls.

169. The airplane must be kept clean the bright structure, this prevents it from overheating.

170. Max difference permitted in the fuel quantity between left and right tank is 10 US gallons for standard tanks.

SUPPLEMENTS(CHAPTER 9)

171. The ELT ACK Model E -01 transmits a distress tone 121.5 MHz and 243 MHz . When it transmits then the red LED flashes.

172. The acceleration indicator activates the ELT when it senses a change in velocity in the Longitudinal Axis.

NOTE: THIS INFORMATION IS TO ASSIST YOU IN PREPARING FOR THE DGCA PAPER ONLY. THE POH REMAINS THE MASTER FOR FLYING AND SUPERSEDES THIS IN CASE OF ANY DISCREPANCY.

THE DA 40 IN A 'CAPSULE'

173. The ELT has a three position switch. ON-OFF-ARMED.
174. The ELT may be activated in turbulence and hard landings.
175. For flight the ELT should be in ARMED mode. In this mode it has no power consumption.
176. The ELT is located on the right side of the fuselage.
177. The ELT battery should be replaced after the transmitter has been operative for more than one cumulative hour.
178. The ELT is independent of the AC electrical system. Power is given to the ELT by 8 batteries.
179. The ARTEX ME 406 ELT if fitted operates on 121.5 Mhz and 406.025 Mhz.
180. The 406.025 Tx transmits for 520 millisecond every 50 sec and sends a message to the satellite.
181. It gives the serial number of the Tx or airplane ID, Country Code and ID code.
182. The 406.025Mhz Tx give a very accurate fix and it is 1-2 kms as compared to the 15-20kms of the 121.5Mhz Tx.

DA 40 AUTOPILOT LIMITS

183. Autopilot must be disengaged below 200 feet AGL during approach operations.
184. The autopilot must be off below 800 feet AGL during all other operations.
185. Maximum fuel imbalance with autopilot with long range tanks is 8 US gallons and 10 US gallons normal tanks.

NOTE: THIS INFORMATION IS TO ASSIST YOU IN PREPARING FOR THE DGCA PAPER ONLY. THE POH REMAINS THE MASTER FOR FLYING AND SUPERSEDES THIS IN CASE OF ANY DISCREPANCY.

THE DA 40 IN A 'CAPSULE'

186. Autopilot maximum engagement speed is 165 KIAS and minimum engagement speed is 70 KIAS.

187. Electric Trim maximum operating speed is 178 KIAS.

188. Maximum height loss due to autopilot failure, flight director failure and AHRS malfunction.

Climb-cruise-descent- 200 feet

Maneuvering - 115 feet

Approach - 130 feet

189. Aircraft speed should be between 70 KIAS and 165 KIAS when using autopilot.

MORE NORMAL PROCEDURES

189. Use external power and preheat when ever ambient temperature is below 0 Deg Celsius.

190. Warm up time is 2-5 minutes at 1500 RPM.

191. Oil pressure should be in green sector within 15 sec of starting up.

192. Starter motor to be operated for a max of 10 sec. Cool for 20 sec before next start. After 6 attempts let the engine cool for 30 minutes.

193. If taxiing close to other ac or if flying in night in clouds, haze, fog, the strobe lights should be switched off.

194. Long range tank correct indication comes on after two minutes of actuating the switch.

195. If the long range tank shows 16 US Gal then select the AUX FUEL QTY switch to left or right. Then add aux quantity to the 16 gallons. Less than 3 US Gallon will not be indicated by the system.

NOTE: THIS INFORMATION IS TO ASSIST YOU IN PREPARING FOR THE DGCA PAPER ONLY. THE POH REMAINS THE MASTER FOR FLYING AND SUPERSEDES THIS IN CASE OF ANY DISCREPANCY.

THE DA 40 IN A 'CAPSULE'

196. Main wheel tire press is 36 PSI and nose wheel is 29 PSI.

197. Fuel pressure should be within 14-35 PSI after start.

198. Above 5000 feet density altitude or at high temperature fully rich mixture causes rough running.

199. Max take off RPM is 2680 +/- 20 RPM.

200. Operating at high altitudes with electrical pump off may cause vapor bubbles.

201. To optimize life of engine CHT should be between 150 deg F and 400 deg F while doing continuous operation. It should not rise above 435 deg F in fast cruise.

202. For continuous operation oil temperature should be between 165 and 220 deg F. Oil temp should not be below 180 deg F for long periods to prevent water accumulation.

203. Maximum CHT permitted is 500 deg F.

204. Before selecting a higher power setting the mixture lever should be slowly moved to fully rich.

204. Best economy mixture. Lowest SFC. Power setting must be only 75%. Lean the engine till it starts running rough. Then adjust till it runs smoothly. The EGT should reach maximum at the same time.

205. Best power mixture. Set Mixture for best economy first. Then enrich till the is lower by 100 deg F. This setting gives maximum performance and is mainly used for high power setting of appx 75%.

206. When reducing power the CHT should not change more than 50 deg F per minute.

NOTE: THIS INFORMATION IS TO ASSIST YOU IN PREPARING FOR THE DGCA PAPER ONLY. THE POH REMAINS THE MASTER FOR FLYING AND SUPERSEDES THIS IN CASE OF ANY DISCREPANCY.

THE DA 40 IN A 'CAPSULE'

21

207. Approach speed 73 for 1200Kg, 71 for 1150 Kg, 63 for 1000 Kg and 58 for 850 kg.
208. Go around speed is 67 for 1200kg, 66 for 1150 kg , 60 for 1000kg and 54 850 kg.
209. If airplane is not operated for 5 days long term parking to be applied and if not operated for 30 days storage procedure to be applied.
210. Flight through rain to be avoided due to visibility problems.
211. High oil press when starting in low temperatures. If it does not reduce then it indicates a faulty indication. Terminate flight.
212. In strong cross wind augment steering with toe brakes. Take off roll will however increase.
213. Engine power falls 3% at ISA+ 15 deg cel and increases 3% at ISA- 15 deg Cel.
214. Max demonstrated cross wind is 20 Kts.
215. For safe take off the TORA should at least equal the take off distance over 50 feet. (TODA)
216. If uphill slope is 2% the take off distance increases by 10%.
217. If the landing mass is above 1150 kg and upto 1200 kg then ground roll will go up by 6 %.
218. The climb gradient of a DA 40 is 7 %.
219. Empty mass is equipment as per inventory, brake fluid, lubricant and unusable (4 liters) fuel.
220. The DA 40 is powered by Lycoming IO-360-M1A: Air cooled four cylinder, four stroke engine. It is horizontally opposed, direct driven with fuel injection system and under slung exhaust.

NOTE: THIS INFORMATION IS TO ASSIST YOU IN PREPARING FOR THE DGCA PAPER ONLY. THE POH REMAINS THE MASTER FOR FLYING AND SUPERSEDES THIS IN CASE OF ANY DISCREPANCY.

THE DA 40 IN A 'CAPSULE'

22

221. In case the governor fails or oil pressure drops then the propeller goes into fine pitch or maximum RPM. Every effort should be made to stop the RPM from crossing 2700 by use of throttle.

222. Rich mixture contributes to engine cooling.

223. Alternate air for engine comes from the engine compartment.

224. There is a mechanical and electrical fuel pump.

225. The electrical pump is used for takeoff, landing, when switching tanks and when fuel pressure is low.

226. For engine restart without electronic ignition then 500 RPM is required.

DGCA has asked questions on the analogue cockpit also. Especially location of switches etc. The cockpit layout with switch numbering is given below.

NOTE: THIS INFORMATION IS TO ASSIST YOU IN PREPARING FOR THE DGCA PAPER ONLY. THE POH REMAINS THE MASTER FOR FLYING AND SUPERSEDES THIS IN CASE OF ANY DISCREPANCY.

THE DA 40 IN A 'CAPSULE'

DA 40 AFM		Airplane Description
-----------	--	-------------------------

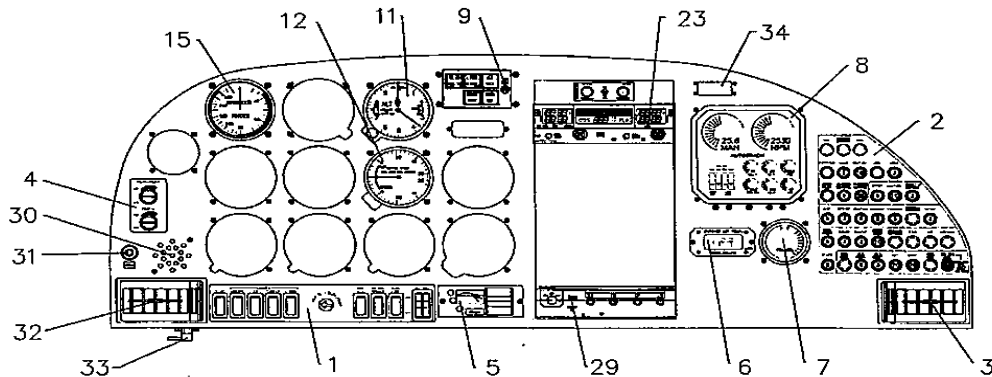

VFR instrument panel (example)

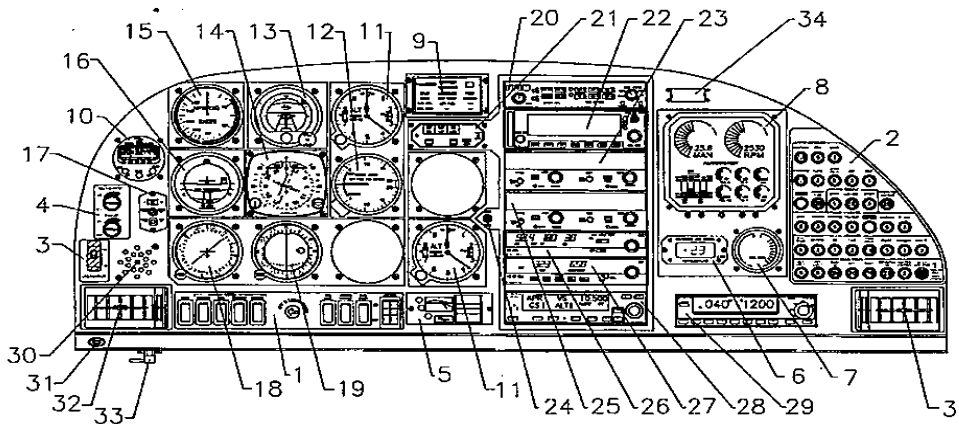

IFR instrument panel (example)

Doc. # 6.01.01-E	Revision 7 15-Jul-2006	Page 7 - 9
------------------	---------------------------	------------

NOTE: THIS INFORMATION IS TO ASSIST YOU IN PREPARING FOR THE DGCA PAPER ONLY. THE POH REMAINS THE MASTER FOR FLYING AND SUPERSEDES THIS IN CASE OF ANY DISCREPANCY.

THE DA 40 IN A 'CAPSULE'

Airplane Description		DA 40 AFM
-------------------------	---	-----------

Major instruments and controls	
1 Electrical switches, ignition switch	18 ADF indicator
2 Circuit breakers*	19 Course deviation indicator (CDI)
3 Emergency switch	20 Audio amplifier / intercom / marker beacon receiver
4 Rotary buttons for instrument lighting and flood light	21 GPS Annunciation Control Unit
5 Flap selector switch	22 GPS
6 OAT indicator	23 Radio / VOR, No. 1
7 Fuel quantity indicator	24 Remote DME switch
8 Engine instruments	25 Radio / VOR, No. 2
9 Lights (Annunciator Panel)	26 DME
10 Chronometer	27 ADF receiver
11 Altimeter	28 Autopilot control unit (optional)
12 Vertical speed indicator (VSI)	29 Transponder
13 Attitude gyro (artificial horizon)	30 Stall warning horn
14 Horizontal situation indicator (HSI)	31 Microphone socket
15 Airspeed indicator	32 Ventilation nozzles
16 Turn & bank indicator	33 Alternate Static Valve (optional for VFR version)
17 Slaving meter	34 ELT operating unit (RCPI)

*) Designations and abbreviations used to identify the circuit breakers are explained in Section 1.5 DEFINITIONS AND ABBREVIATIONS.

Page 7 - 10	Revision 7	15-Jul-2006	Doc. # 6.01.01-E
-------------	------------	-------------	------------------

NOTE: THIS INFORMATION IS TO ASSIST YOU IN PREPARING FOR THE **DGCA PAPER ONLY**. THE **POH** REMAINS THE **MASTER** FOR FLYING AND SUPERSEDES THIS IN CASE OF ANY DISCREPANCY.

THE DA 40 IN A 'CAPSULE'

Question Bank-Tech Specific DA-40-DGCA July Exam

25

1. An aircraft including maximum oil, all consumables and maximum fuel
 - a) empty mass
 - b) max t/o weight
 - c) max landing weight
2. C of A is issued in the form
 - a) C.23
 - b) C.23A
 - c) C.23A & AFM
3. +ve load factor for normal category at Va & Vne
 - a) 3.8 & 3.8
4. Instrument no 11 and no 19 in the conventional instrument panel
 - a) altimeter and slaving meter
5. Which button will show display mode
 - a) Button 1 [engine soft key in MFD]
6. Above which airspeed is restarting engine is possible
 - a) 70 kts
7. Airspeed for 1200 kgs, 1000 kgs, 850kgs
8. Sec 3 of POH is " emergency procedures"
9. Engine is
 - a) Lycoming IO-260-M1A air cooled 4 stroke
 - b) Lycoming IO-360-M1A air cooled 4 stroke
 - c) Lycoming IO-360-M2A air cooled 4 stroke
 - d) Lycoming IO-360-M1A air cooled 2 stroke
10. 26° F & 317° F : shows
Fault lies with oil temperature sensor.
11. Green in ASI :
 - a) 52-129
 - b) 129- 91
 - c) 50- 120
 - d) 49-91
12. Max continuous RPM : 180 BHP
13. Va for 1150 Kg
 - a) 111
 - b) 94
 - c) 110
 - d) 90
14. AOB should not be performed in normal & utility Cat.
 - a) 60° & 90°

NOTE: THIS INFORMATION IS TO ASSIST YOU IN PREPARING FOR THE DGCA PAPER ONLY. THE POH REMAINS THE MASTER FOR FLYING AND SUPERSEDES THIS IN CASE OF ANY DISCREPANCY.

THE DA 40 IN A 'CAPSULE'

15. What is the ideal Cg position 2.194m
16. Switch for electrically adjusted rudder pedals is situated at
 - a) rear of the leg room
 - b) front of leg room
 - c) side of instrument panel
17. In how many sec must the oil pressure be registered after start up
18. Color of taxi lights
19. Life of emergency battery
20. Why should not the oil temperature remain under 180°F for long periods
Avoid accumulation of condensation of water
21. Strong crosswind steering is augmented by use of toe brakes
22. C of A is issued on CA23
23. Max fuel indication in Sl.No.40.055.....
24. Max bank angle in utility & normal category
25. Distance of datum plane.....
26. On approach at which altitude auto pilot must be disengaged.....
27. Max landing mass.....
28. At what voltage does the warning indication comes on.....
29. A stable oil temperature indications of 26°F or 317°F indicates.....
30. Third section of the AFM is.....
31. Speed at which T/O cannot be abandoned
32. Ht at which autopilot can be engaged.
33. Airspeed to restart engine
34. Green arc range of the ASI is.....
35. Max allowable difference in fuel tank(long range)
36. High oil pressure indications and the oil temperature remains normal the probable reason is.....
37. If electric rudder pedal adjustment fails, check the circuit breaker
38. Approach speed with high landing mass 1200kgs is 73KIAS
39. If "low voltage" caution during flight occurs check ammeter indications for zero indications.
40. Emergency procedures are in POH chapter 3.
41. Empty mass
42. Maneuvering speed
43. Vfe
44. C.G LIMITS
45. Operation time of electrical equipment in case of electrical failure
46. emergencies airspeed till 1000kg no airspeed about 850kg was asked
47. RE starting the engine with wind milling propeller(speed)
48. glide ratio

NOTE: THIS INFORMATION IS TO ASSIST YOU IN PREPARING FOR THE DGCA PAPER ONLY. THE POH REMAINS THE MASTER FOR FLYING AND SUPERSEDES THIS IN CASE OF ANY DISCREPANCY.

THE DA 40 IN A 'CAPSULE'

49. touch and go speed
50. BEST economy mixture
51. best power mixture
52. go-around speed
53. An uphill slope of 2% increase t/o dist of approx 10%
54. take off dist. over 50ft obstacle(graph)
55. for a safe landing distance available should be at least equal to the landing dist. over 50 ft obstacle
56. location of datum plane
57. min. and max auto pilot engage and disengage speed
58. Two questions about the conventional cockpit name the instruments very simple
59. CO indications.